



POWERING INNOVATION THAT DRIVES HUMAN ADVANCEMENT

© 2025 ANSYS, Inc. or its affiliated companies
Unauthorized use, distribution, or duplication is prohibited.

Getting Started with EMIT - Tutorial 3



ANSYS, Inc.
Southpointe
2600 Ansys Drive
Canonsburg, PA 15317
ansysinfo@ansys.com
<https://www.ansys.com>
(T) 724-746-3304
(F) 724-514-9494

Release 2025 R2
July 2025

ANSYS, Inc. and
ANSYS Europe,
Ltd. are UL
registered ISO
9001:2015 com-
panies.

Copyright and Trademark Information

© 1986-2025 ANSYS, Inc. Unauthorized use, distribution or duplication is prohibited.

ANSYS, Ansys Workbench, AUTODYN, CFX, FLUENT and any and all ANSYS, Inc. brand, product, service and feature names, logos and slogans are registered trademarks or trademarks of ANSYS, Inc. or its subsidiaries located in the United States or other countries. Icem CFD is a trademark used by ANSYS, Inc. under license. All other brand, product, service and feature names or trademarks are the property of their respective owners. FLEXIm and FLEXnet are trademarks of Flexera Software LLC.

Disclaimer Notice

THIS ANSYS SOFTWARE PRODUCT AND PROGRAM DOCUMENTATION INCLUDE TRADE SECRETS AND ARE CONFIDENTIAL AND PROPRIETARY PRODUCTS OF ANSYS, INC., ITS SUBSIDIARIES, OR LICENSORS. The software products and documentation are furnished by ANSYS, Inc., its subsidiaries, or affiliates under a software license agreement that contains provisions concerning non-disclosure, copying, length and nature of use, compliance with exporting laws, warranties, disclaimers, limitations of liability, and remedies, and other provisions. The software products and documentation may be used, disclosed, transferred, or copied only in accordance with the terms and conditions of that software license agreement.

ANSYS, Inc. and ANSYS Europe, Ltd. are UL registered ISO 9001: 2015 companies.

U.S. Government Rights

For U.S. Government users, except as specifically granted by the ANSYS, Inc. software license agreement, the use, duplication, or disclosure by the United States Government is subject to restrictions stated in the ANSYS, Inc. software license agreement and FAR 12.212 (for non-DOD licenses).

Third-Party Software

See the legal information in the product help files for the complete Legal Notice for Ansys proprietary software and third-party software. If you are unable to access the Legal Notice, please contact ANSYS, Inc.

Conventions Used in this Guide

Please take a moment to review how instructions and other useful information are presented in this documentation.

- Procedures are presented as numbered lists. A single bullet indicates that the procedure has only one step.
- Bold type is used for the following:
 - Keyboard entries that should be typed in their entirety exactly as shown. For example, “**copy file1**” means you must type the word **copy**, then type a space, and then type **file1**.
 - On-screen prompts and messages, names of options and text boxes, and menu commands. Menu commands are often separated by greater than signs (>). For example, “click **HFSS > Excitations > Assign > Wave Port.**”
 - Labeled keys on the computer keyboard. For example, “Press **Enter**” means to press the key labeled **Enter**.
- Italic type is used for the following:
 - Emphasis.
 - The titles of publications.
 - Keyboard entries when a name or a variable must be typed in place of the words in italics. For example, “**copy filename**” means you must type the word **copy**, then type a space, and then type the name of the file.
- The plus sign (+) is used between keyboard keys to indicate that you should press the keys at the same time. For example, “Press Shift+F1” means to press the **Shift** key and, while holding it down, press the **F1** key also. You should always depress the modifier key or keys first (for example, Shift, Ctrl, Alt, or Ctrl+Shift), continue to hold it/them down, and then press the last key in the instruction.

Accessing Commands: *Ribbons*, *menu bars*, and *shortcut menus* are three methods that can be used to see what commands are available in the application.

- The *Ribbon* occupies the rectangular area at the top of the application window and contains multiple tabs. Each tab has relevant commands that are organized, grouped, and labeled. An example of a typical user interaction is as follows:

"Click **Schematic > Line**"



This instruction means that you should click the **Line** command on the **Schematic** ribbon tab. An image of the command icon, or a partial view of the ribbon, is often included with the instruction.

- The *menu bar* (located above the ribbon) is a group of the main commands of an application arranged by category such File, Edit, View, Project, etc. An example of a typical user interaction is as follows:

"On the **File** menu, click the **Open Examples** command" means you can click the **File** menu and then click **Open Examples** to launch the dialog box.

- Another alternative is to use the *shortcut menu* that appears when you click the right-mouse button. An example of a typical user interaction is as follows:

"Right-click and select **Assign Excitation> Wave Port**" means when you click the right-mouse button with an object face selected, you can execute the excitation commands from the shortcut menu (and the corresponding sub-menus).

Getting Help: Ansys Technical Support

For information about Ansys Technical Support, go to the Ansys corporate Support website, <http://www.ansys.com/Support>. You can also contact your Ansys account manager in order to obtain this information.

All Ansys software files are ASCII text and can be sent conveniently by e-mail. When reporting difficulties, it is extremely helpful to include very specific information about what steps were taken or what stages the simulation reached, including software files as applicable. This allows more rapid and effective debugging.

Help Menu

To access help from the Help menu, click **Help** and select from the menu:

- **[product name] Help** - opens the contents of the help. This help includes the help for the product and its *Getting Started Guides*.
- **[product name] Scripting Help** - opens the contents of the *Scripting Guide*.
- **[product name] Getting Started Guides** - opens a topic that contains links to Getting Started Guides in the help system.

Context-Sensitive Help

To access help from the user interface, press **F1**. The help specific to the active product (design type) opens.

You can press **F1** while the cursor is pointing at a menu command or while a particular dialog box or dialog box tab is open. In this case, the help page associated with the command or open dialog box is displayed automatically.

Table of Contents

Table of Contents	Contents-1
1 - Introduction	1-1
Key Concepts	1-1
Project Configuration	1-1
2 - Add a Transceiver (RT) to the Scenario and Mitigate Interference	2-1
3 - Add Additional Tx's to the Scenario	3-1

1 - Introduction

This example builds on the project developed in Tutorial 1 to introduce additional modeling concepts and features in EMIT. You can find a completed version of the Tutorial 1 project in the installed examples directory by clicking on **Open Examples** in the Desktop ribbon toolbar.

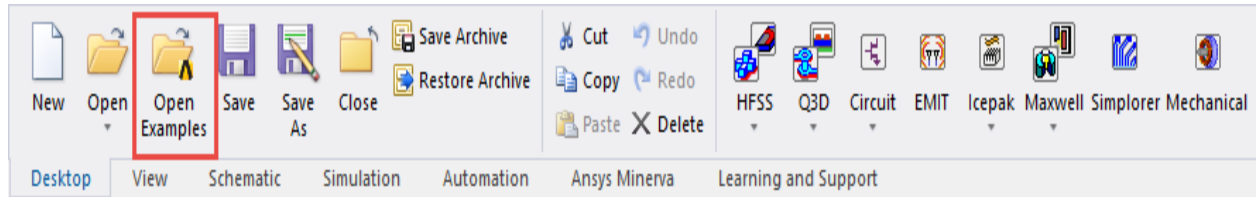

Key Concepts

- Building and analyzing scenarios with multiple Tx's and Rx's
- EMIT's N-on-1 analysis mode
- Outboard amplifiers
- Interference due to intermodulation effects

Project Configuration

For this example, we will again modify the project built in Tutorial 1. Load that project into EMIT and save it as "Tutorial 3" by selecting Save As from the File menu.

We will be adding several additional RF systems to this project and examining the effect of multiple Tx's operating simultaneously and their effect on a victim Rx. Along the way we'll explore various mitigation strategies to combat interference, eventually arriving at a completely interference-free scenario. The final scenario is shown notionally in the figure below. Note that since we are still using a fixed value (Global Default Coupling = -40 dB in this case) of coupling between all antennas, the actual physical location of the antennas is irrelevant (Tutorial 4 explores EMIT's other antenna-to-antenna coupling models).

Up until now we have only looked at the effects of a single Tx on a Rx. When we look at multiple, simultaneously operating Tx's on a victim Rx, we not only have to account for the direct signal from each Tx combining at the Rx antenna, but also the effects of inter-Tx coupling – that is, of signals coupling between the Tx's and re-radiating to the victim Rx. This is of concern because when multiple signals couple into the front-end of a Tx, nonlinear effects in the Tx's power amplifier (PA) can generate undesired intermodulation products that can cause interference even when the individual signals do not. We will see this first-hand during this example.

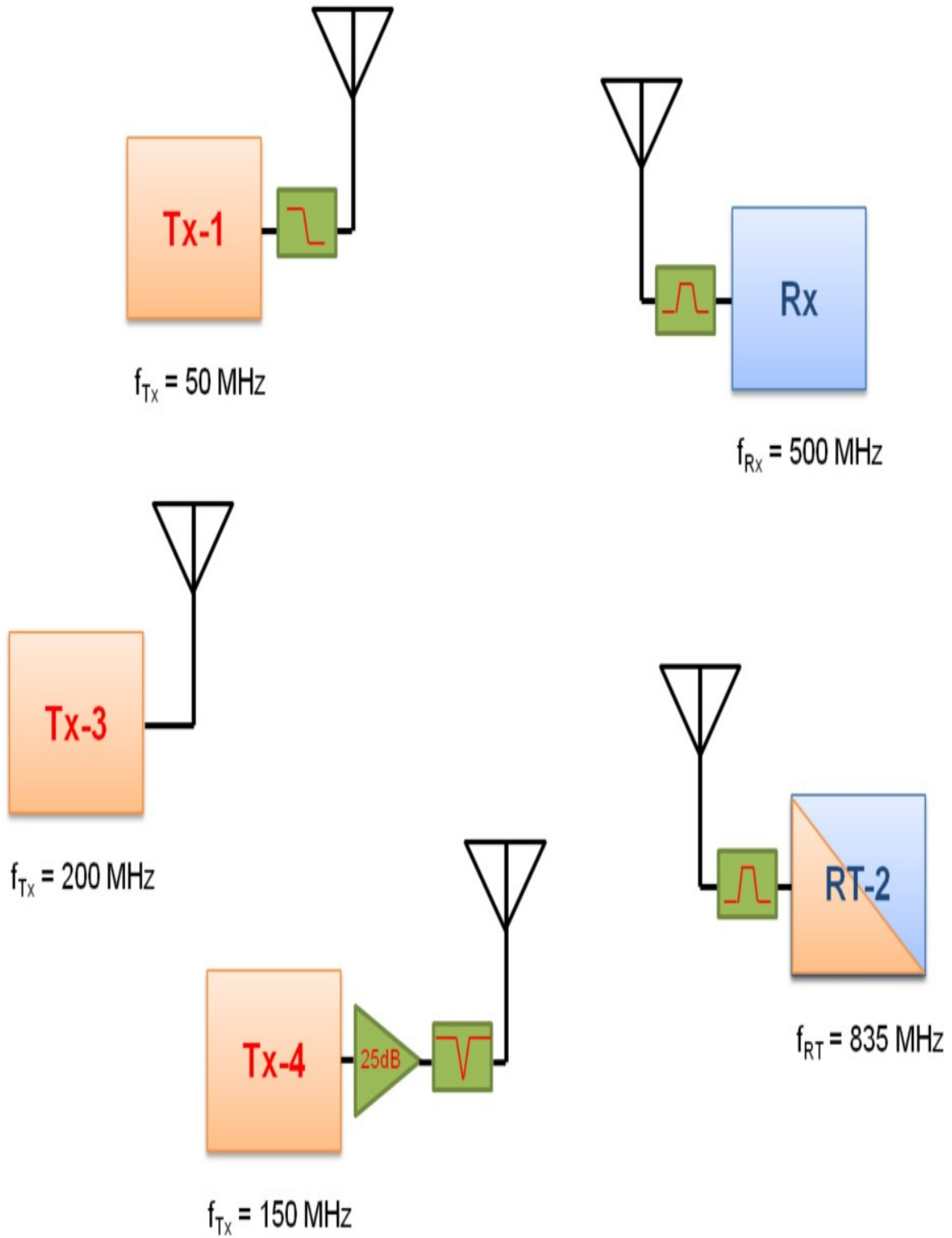

2 - Add a Transceiver (RT) to the Scenario and Mitigate Interference

To begin, we will add a Radio to the scenario. Select the **Schematic** tab in the ribbon toolbar and then add a New Radio from the **Radio** drop-down menu. Select the new radio and in the Properties panel and rename it RT-2.

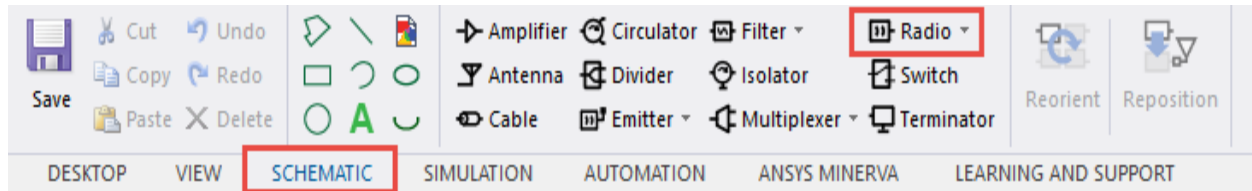

Double-click on the radio in the schematic or right-click and select **Configure** to configure the radio. Set the parameters for the Band, Tx Spectral Profile and Rx Spectral Profile as shown below, being careful to copy all the parameters as shown. Note that the Tx Broadband Noise = -185 dBm/Hz. This is clearly below the theoretical noise floor limit of -174 dBm/Hz and is only configured this way to simplify the results analysis later on in this example.

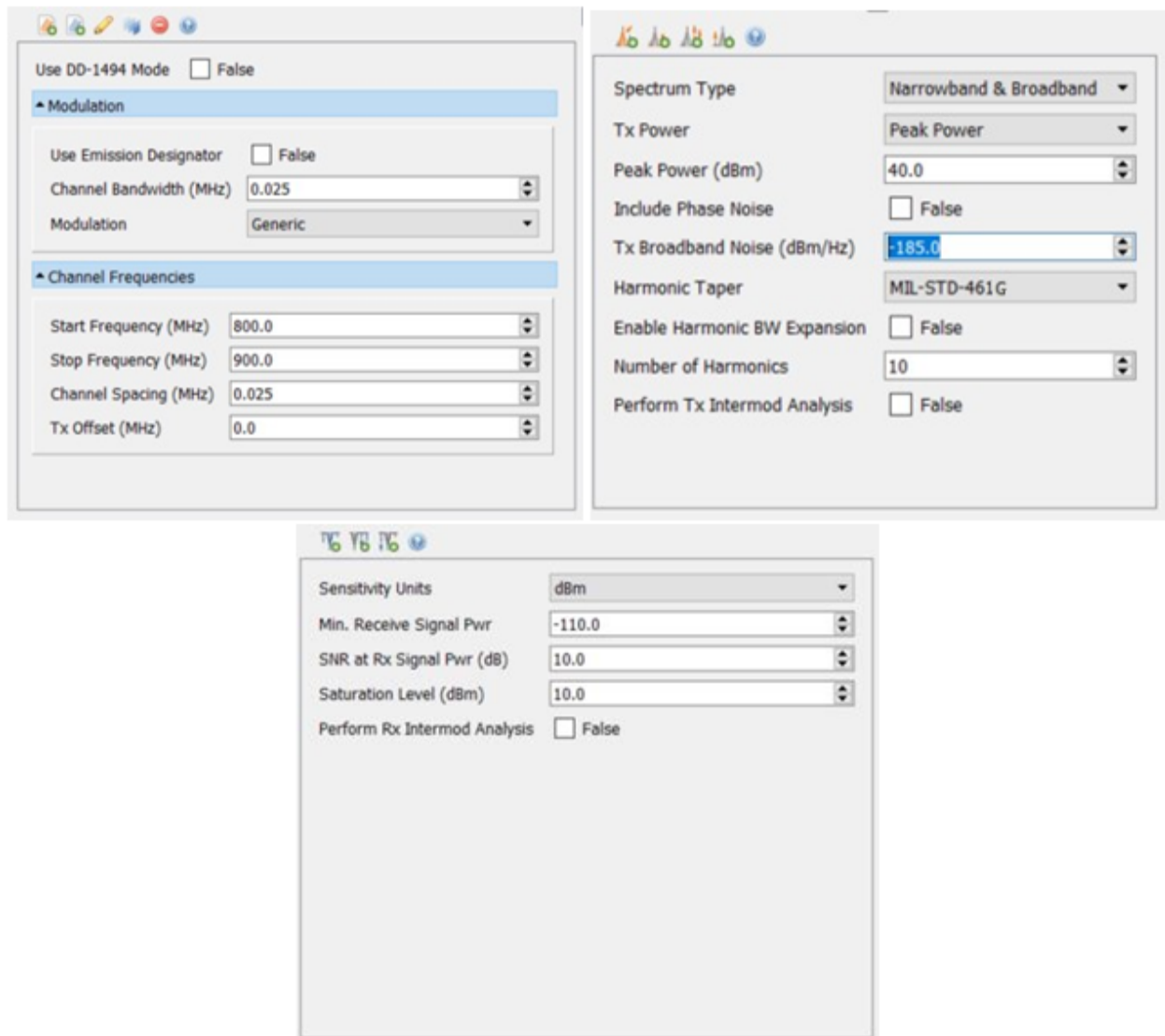

We also want to model the IF frequency, mixer products, and IF filters for this Band. Right-click on the Rx Spectral Profile and select **Add Mixer Products**. Then right-click on the Rx Spectral Profile node and select **Rx Selectivity**. Configure these nodes as shown below.

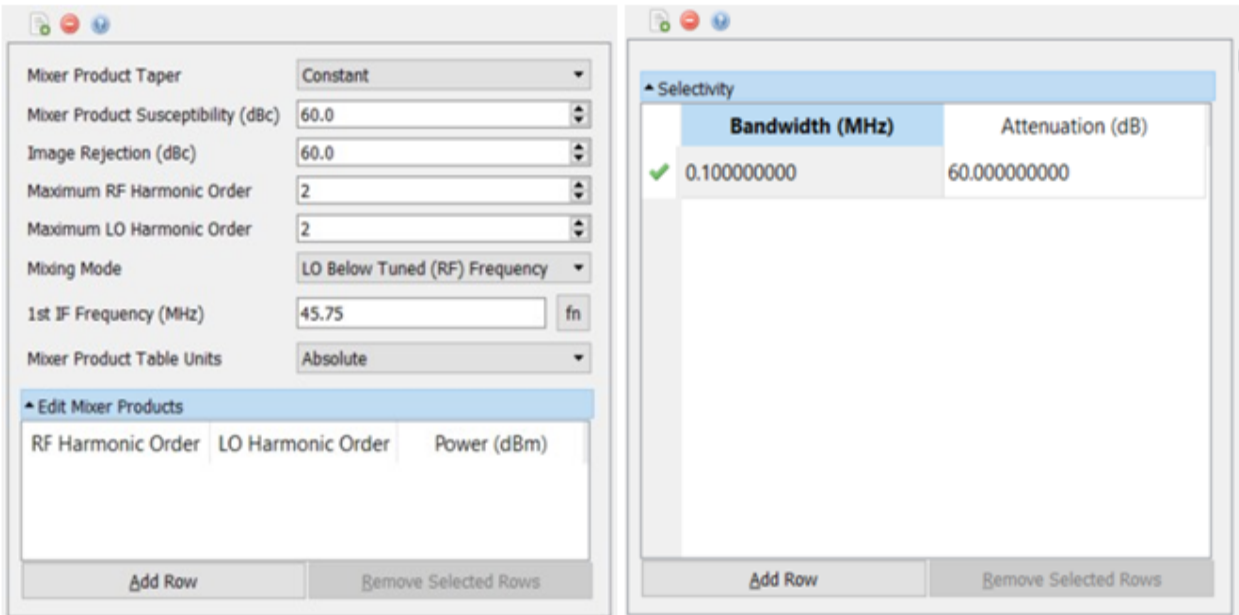

Next, select the Sampling for the RT-2 (Hi-UHF) radio and set the values as shown below.

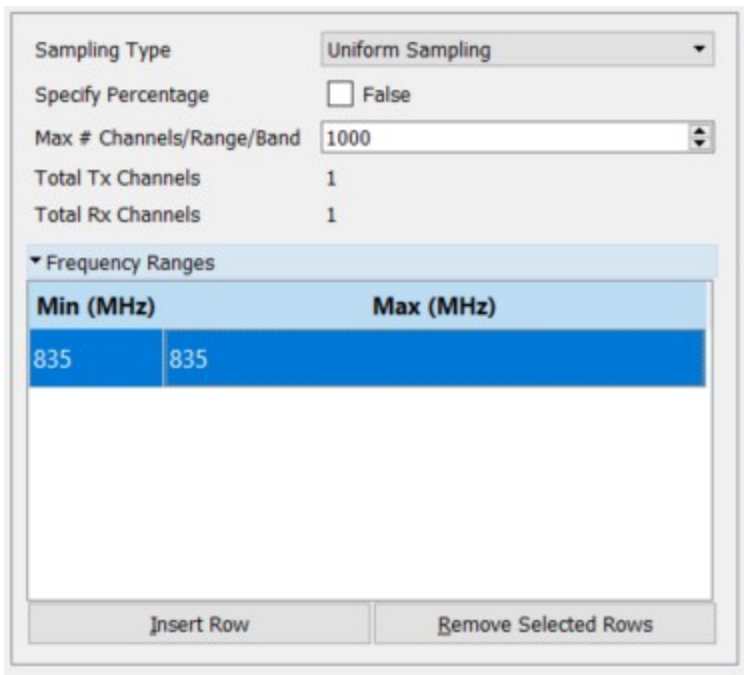

Click the X to close the Radio Configuration dialog box. Next, use the ribbon toolbar to add an antenna to the RT-2 radio. If the antenna is not automatically connected to the output port of the RT-2 radio, then reposition it. The schematic should appear as shown below.

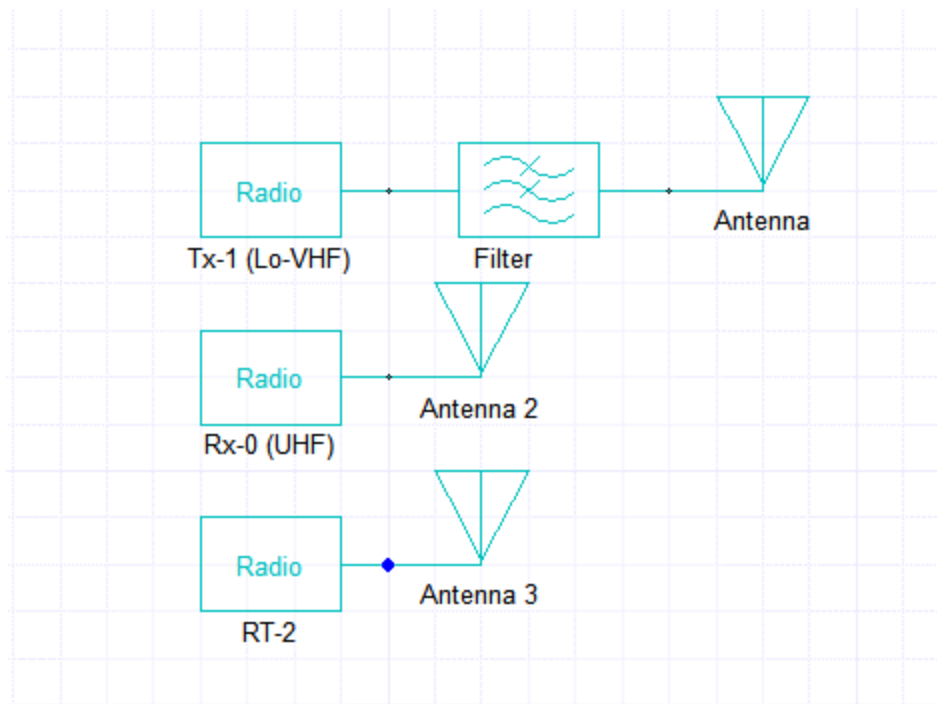

Before continuing, we want to modify our antennas so that they do not contribute any ambient noise to the simulation results (for simplicity). Double-click on one of the antennas in the schematic to open the Coupling Editor.

Set the Antenna Temperature = 0 K in the property panel for the selected antenna. Then repeat for the other two antennas.

Click the X to close the Coupling Editor. From the **Simulation** tab of the ribbon toolbar, select **Analyze** to open a results dialog box.

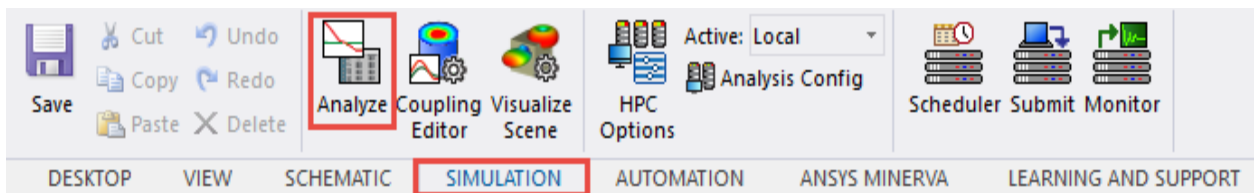

Move the **N to 1 Combination Limit** slider to the left.



By default, self-interactions for transceivers are disabled. Right-click on the RT-2 self-interaction square in the Scenario Matrix and select Enabled. In this example, there is no external path from

the RT-2 transmitter to the RT-2 receiver and therefore it has a warning in the Scenario Matrix. Since we are not interested in the transceiver's self-interference, right-click on the RT-2 self-interaction square again and deselect Enabled. The Scenario Matrix should appear as shown below.

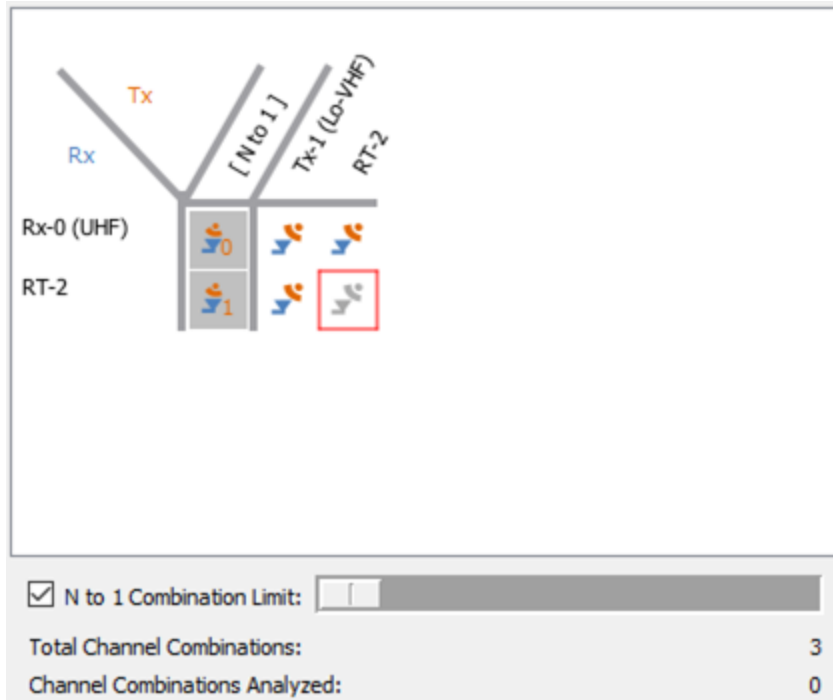

Any analysis corresponding to a square in the threat matrix can be toggled between active and inactive by clicking on the square while holding down the control key or by right-clicking on the square and selecting (or deselecting) the Enabled option. In this way, the specific analyses that are run by EMIT can be easily controlled.

In some cases, we may wish to have EMIT flag EMI margins that are less than zero in order to build a safety margin of sorts into the analysis or flag EMI margins above a certain threshold (e.g. +50 dB) as “critical” EMI problems. For this project, we will have EMIT flag any EMI margins < -10 dB as interference free (green), EMI margins between -10 dB and 0 dB as marginal (yellow), and EMI margins > 0 dB as interference (red). To do this select the By EMI Margin tab in the upper right corner of the Results dialog box. If the values on this tab do not match these settings, then reconfigure them now.

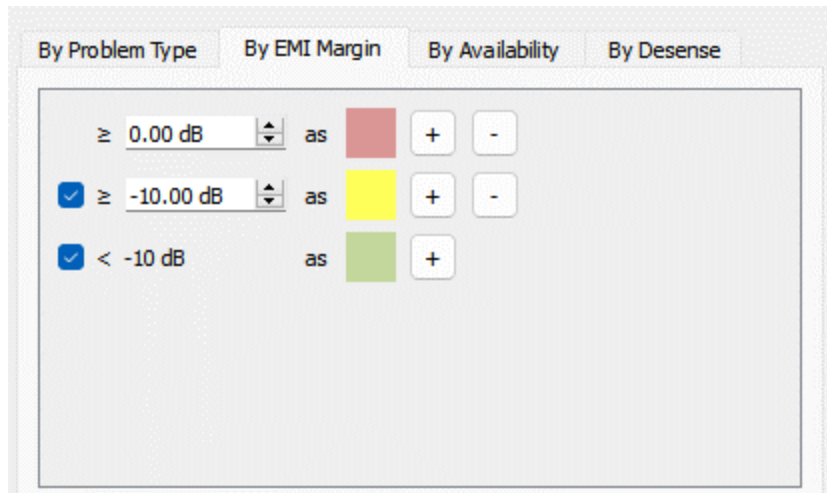

Run all the analyses by clicking on the icon in the toolbar at the top of the Results dialog. The Scenario Matrix is shown below. Recall that the pop-up showing the Max EMI margin for any flagged entry in the threat matrix can be obtained by hovering the cursor over the square momentarily.

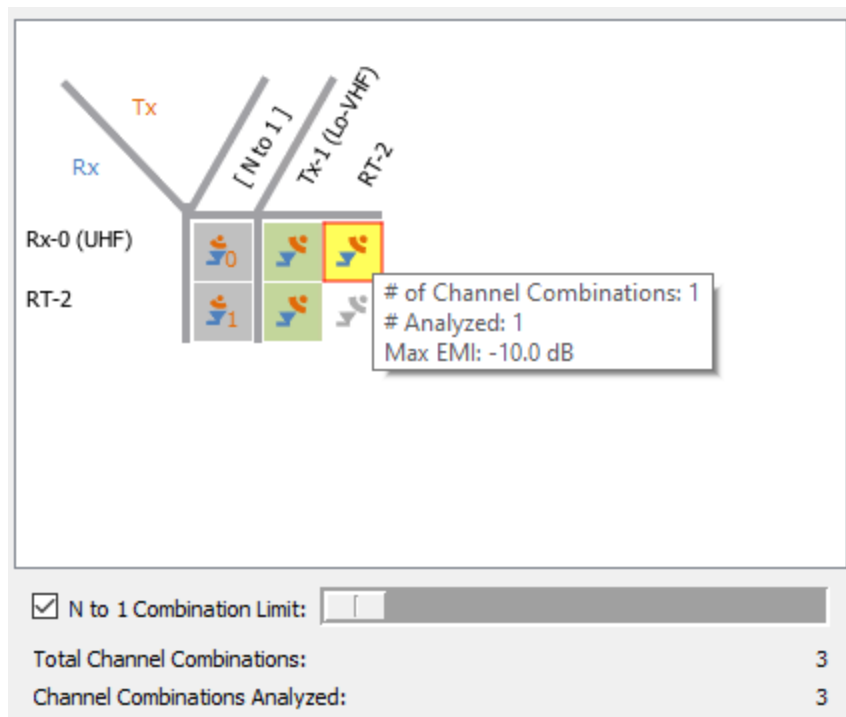

From the threat matrix, we see that when RT-2 transmits at 835 MHz there is the potential for interference with a -10 dB EMI margin in Rx-0, which is operating at 500 MHz. To further investigate this issue, we will use some of the other displays in the Results dialog, notably the Results

Plot. By default, the Results Plot will show the worst-case interference for the square that is selected in the Scenario Matrix. If no square is selected, then the worst-case interference for the entire scenario will be displayed. If the square for the RT-2 vs Rx-0 (UHF) interaction is not already selected, then do so now and observe any changes in the Results Plot.

Note that you can change the line width on the traces in the plot by clicking on the legend labels at the bottom, below the plot. For example, click on the “Receiver Susceptibility” legend name and the blue Rx susceptibility trace in the plot will be highlighted as shown below. By doing this for various traces it is easy to identify where spectral features overlap. In this case, we see that the Tx fundamental falls within a low-level Rx spurious response at 835 MHz which is the cause of the interference. This would be considered out-of-channel interference since the interfering signal is outside the Rx’s tuned channel bandwidth.

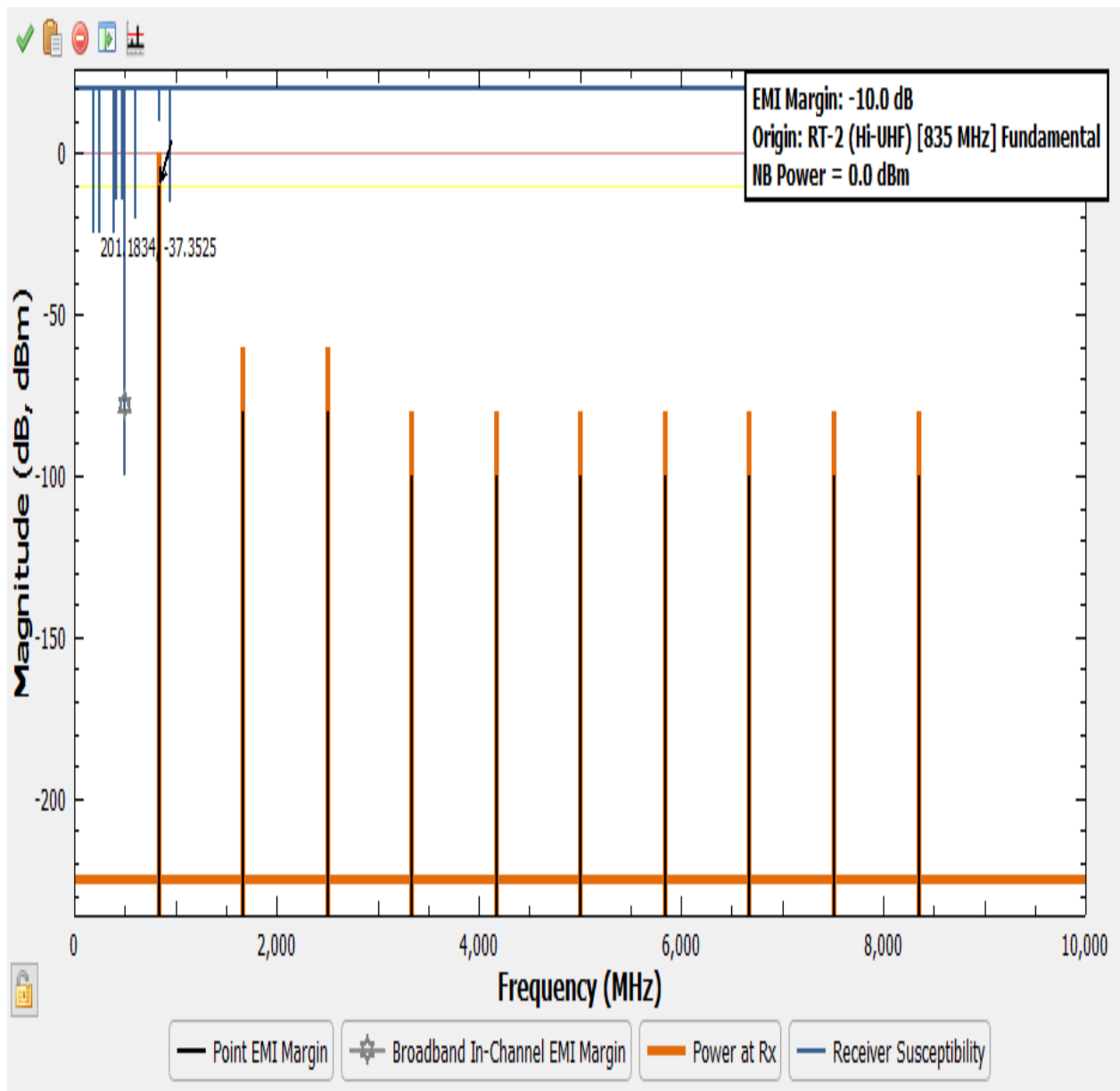

Aside from reducing the Tx power, there isn't anything that can be done at the Tx (RT-2 in this case) to mitigate the problem. Any mitigation must take place at the Rx. In this case we can add a bandpass filter to the Rx to prevent the out-of-channel signals from getting into the Rx front-end. Click the "X" in the upper corner of the Results dialog to return to the schematic. Note that EMIT automatically saves the results and that they will not be lost. To view the results again, simply right-click on the result in the Project Tree and select **Show Current Result**. Note that your revision number may be different.

To save a snapshot of the scenario at any instant, right-click on the **Results** folder and select **Keep Current Result**. To help organize and maintain multiple results, EMIT allows each kept result to be renamed and for notes to be added.

Right-click the **Results** folder and select **Keep Current Result**. Rename the result to Preliminary Analysis, then in the **Properties** panel, select **Edit Notes** and add some comments that describe the current scenario and results.

Note:

The project may contain some kept results from Tutorial 1. These can be optionally kept or deleted.

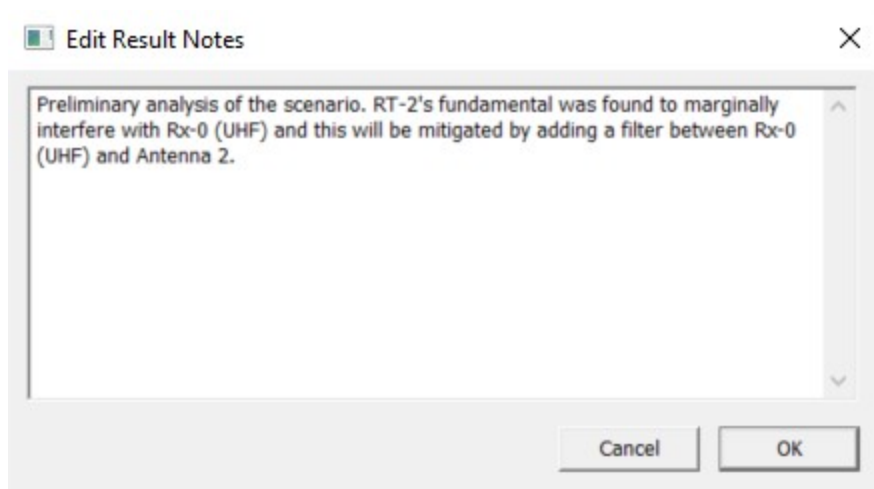

Next, we want to add a bandpass filter at the output of Rx-0 (UHF) to mitigate the interference we observed. To do this, drag Antenna 2 to the left of Rx-0 (UHF) and release the left mouse button. This will delete the wire connecting the radio and antenna. Then select the Rx-0 (UHF) radio in the schematic and then add a Band Pass filter from the Filter drop down menu. These steps should ensure that the filter automatically gets placed and connected at the radio's output. Finally, select Antenna 2 and then click **Reposition** in the Schematic ribbon toolbar. Since the right-side port of the bandpass filter is the only unconnected port, Antenna 2 will automatically be repositioned and connected here. The schematic should now show:

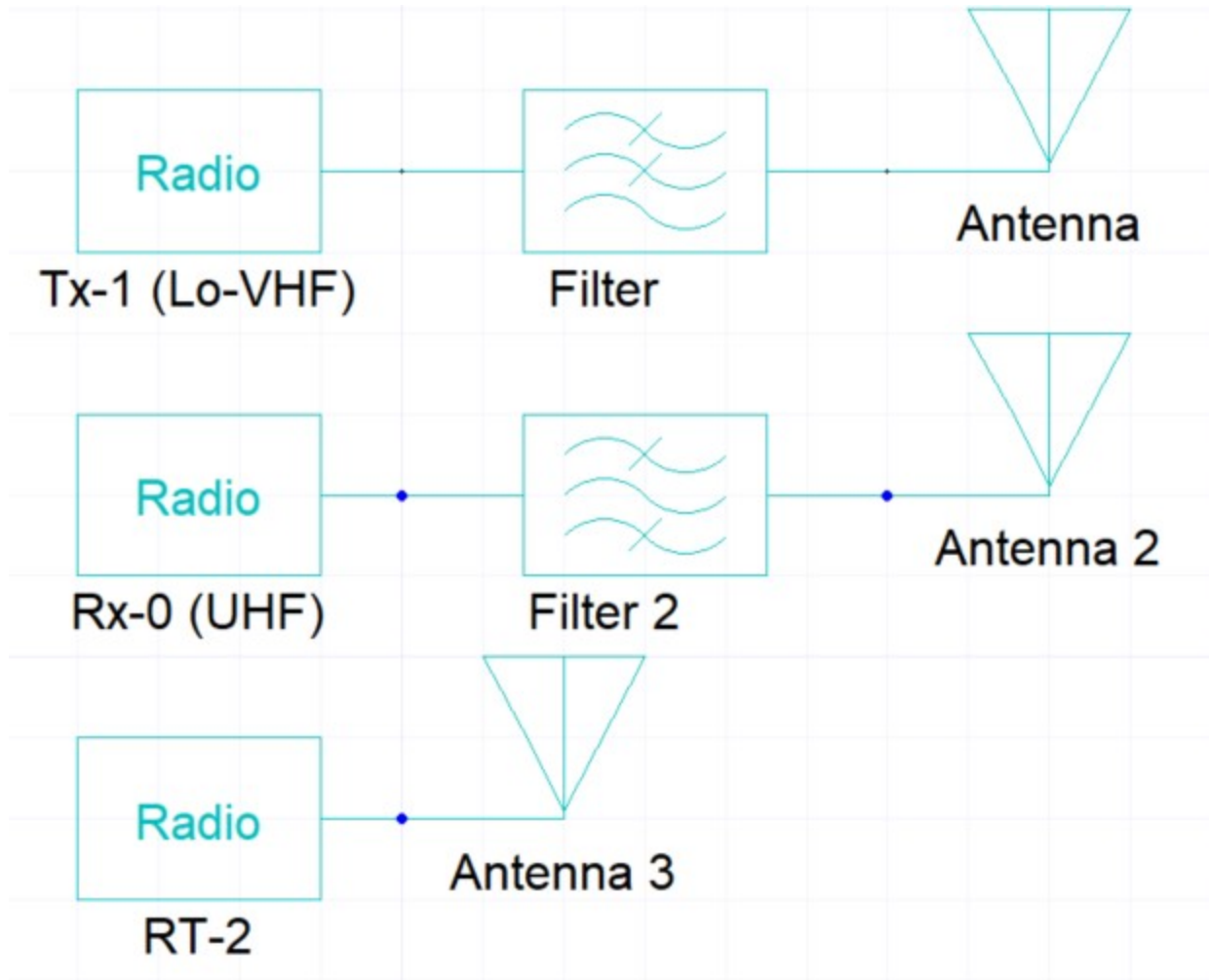

In the Properties panel, set the bandpass filter's name to *UHF Bandpass Filter*. Then right-click on the bandpass filter (Filter 2 above) and select **Configure**. Set the filter's parameters as shown below and then click the X to close the edit dialog box.

Noise Temperature (K)	290.0
Type	Band Pass
Insertion Loss (dB)	1.0
Stop band Attenuation (dB)	40.0
Lower Stop Band (MHz)	490.0
Lower Cutoff (MHz)	495.0
Higher Cutoff (MHz)	505.0
Higher Stop Band (MHz)	510.0
↑Notes	
<div style="border: 1px solid black; height: 80px;"></div>	

From the **Simulation** tab of the ribbon toolbar, select **Analyze** to open the **Results** window.

In the results window, re-run the simulation. The Scenario Matrix should now have all green squares, signifying that all the current interference problems were mitigated. Close the results dialog box using the X in the upper right corner. Right-click on the **Results** folder and select **Keep Current Result**. Rename the kept result *Preliminary Analysis - Mitigated*.

3 - Add Additional Tx's to the Scenario

We will now add two additional transmitters to the scenario and include an outboard power amplifier on one of them. From the Schematic tab in the ribbon toolbar, select New Radio from the Radio drop down menu and name the radio Tx-3 (Lo-UHF). To configure the radio so that it is a transmitter only, right-click and open its Configuration dialog. Then, expand the Band node and disable the Rx Spectral Profile. Finally, set its operating parameters as shown in the Band, Tx Spectral Profile and Sampling nodes below. After entering the parameters, click the X to close the Configuration dialog box.

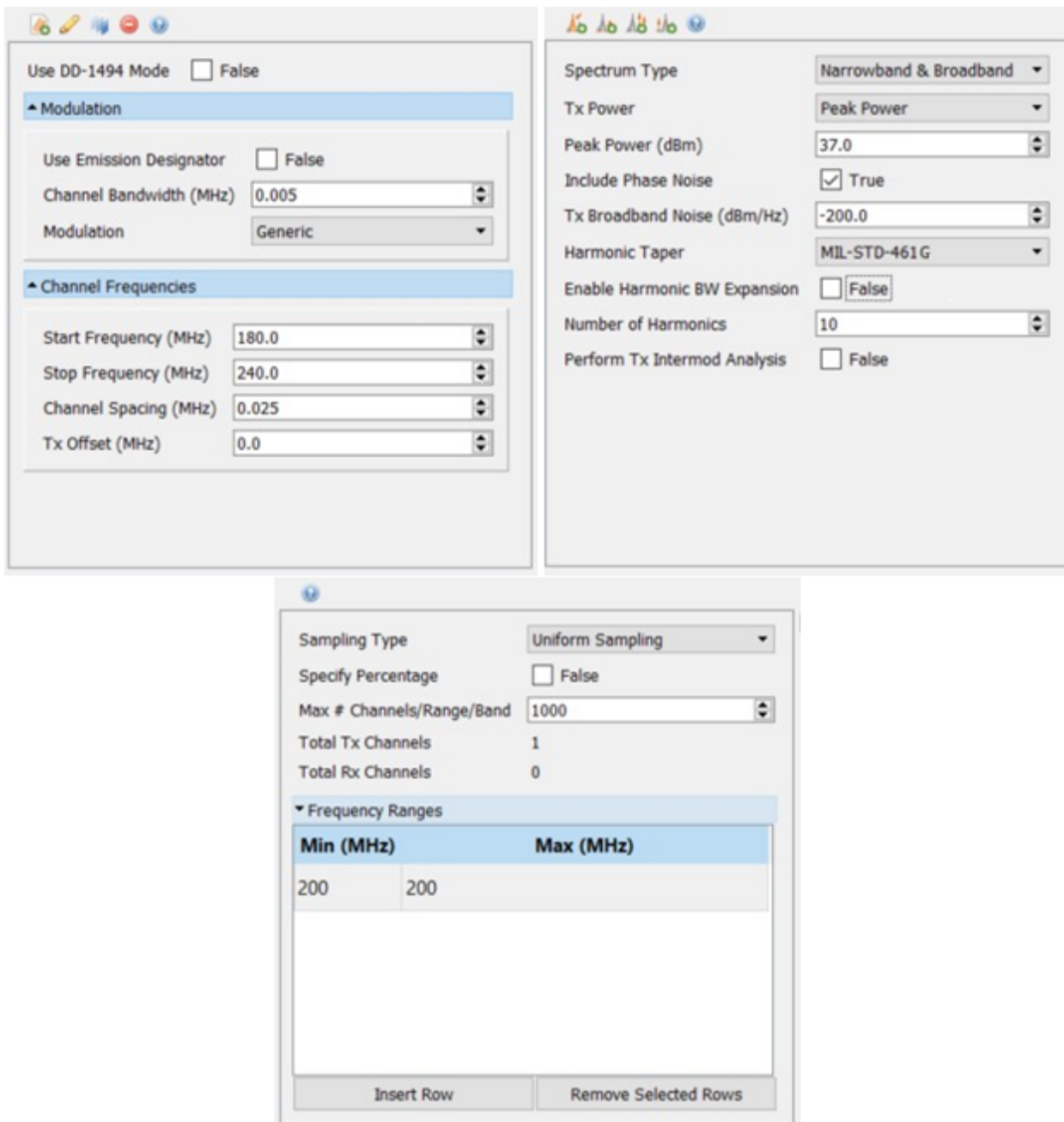

Repeat the above steps to add another radio named Tx-4 and set its parameters as shown below.

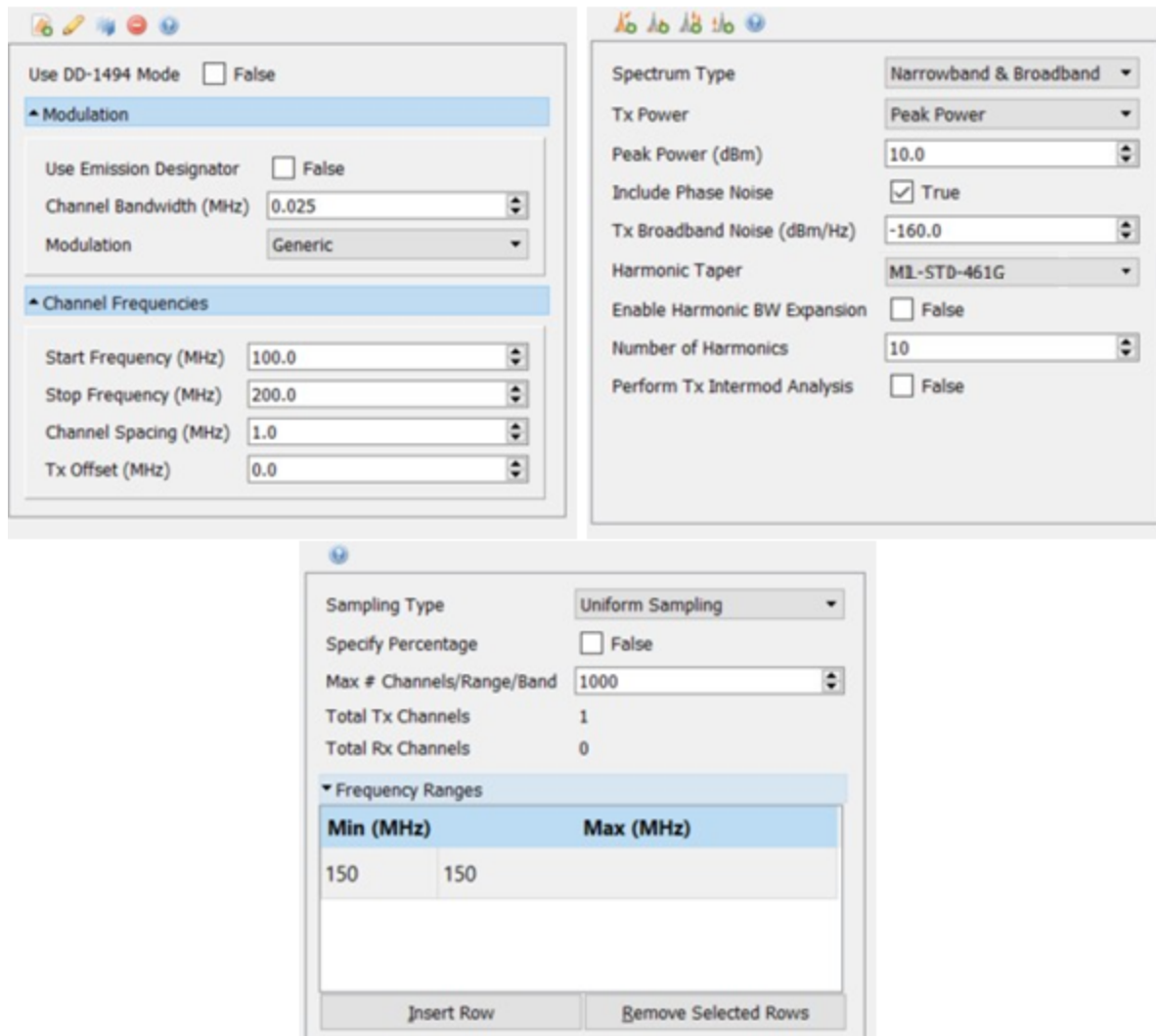

Note the relatively low (10 dBm) power level of Tx-4 indicating that it is a low-level exciter. We want to add an external RF power amplifier to this transmitter to boost the power. In the Schematic ribbon toolbar, click the Amplifier icon to insert an amplifier. If it is not connected to Tx-4, then click **Reposition** to automatically move it. Double-click on the new amplifier to configure it with the parameters below. Detailed explanations for each of these parameters can be found in the amplifier section of the EMIT help. Clicking Help (?) above the amplifier's property panel will take you directly to the amplifier online help.

Noise Temperature (K)	290.0
Gain (dB)	40.0
Center Frequency (MHz)	150.0
Bandwidth (MHz)	75.0
Noise Figure (dB)	5.0
Saturation Level (dBm)	20.0
1-dB Point, Ref. Input (dBm)	20.0
IP3, Ref. Input (dBm)	30.0
Shape Factor (30dB/3dB)	2.0
Reverse Isolation (dB)	20.0
Max Intermod Order	5

^Harmonic Intercept Points, Ref. Input

Harmonic	Intercept Point
----------	-----------------

Add Row Remove Selected Rows

^Notes

Before continuing with the analysis, we will examine the characteristics and features of the amplifier in some additional detail. EMIT's amplifier model takes into account the nonlinear behavior of the amplifier. When multiple signals are present at the input of the amplifier, not only do amplified versions of those signals appear at the output, but intermodulation products (intermod) generated by the nonlinear characteristics of the amplifier are also generated and appear at the output. Further, the model uses the reverse isolation of the amplifier to account for signals entering the output of the amplifier. This is very important to include for cosite interference predictions since it is the mechanism by which inter-Tx intermod is generated and re-radiated. We will see this phenomenon first-hand when we analyze our scenario.

If the input signals to an amplifier exceed the 1-dB point, then EMIT will consider the amplifier to be saturated and will treat this saturated condition as an interference event. The results will report the saturated condition of the amplifier instead of an EMI margin.

The plotting functionality for an amplifier has some unique characteristics to allow the performance of an amplifier to be easily explored as it is being defined. The plot currently shown in the amplifier's configuration dialog should look similar to the one below.

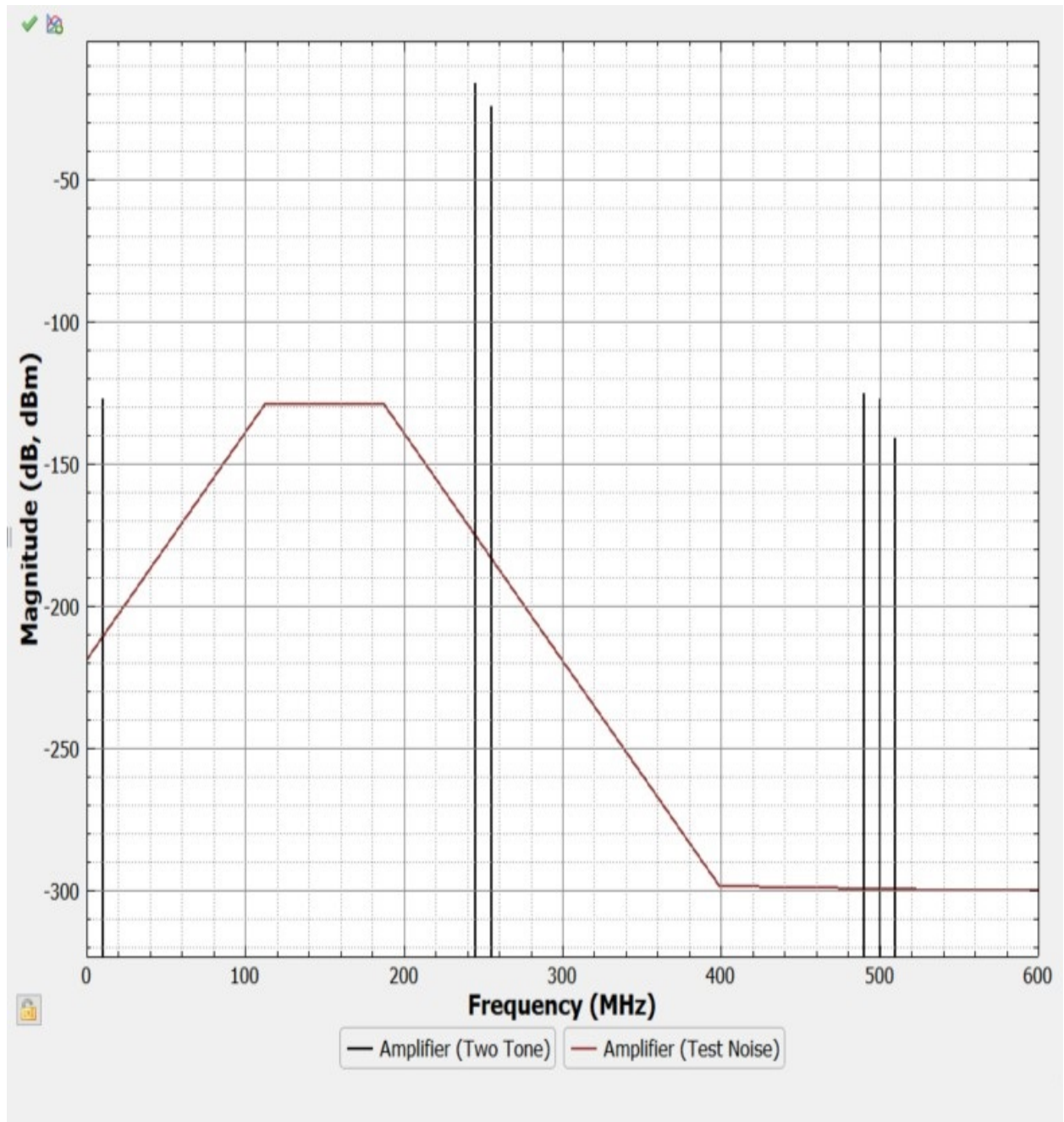

The plot displays the amplifier's output spectrum due to an input signal consisting of constant broadband noise and two narrowband tones. This mimics a typical two-tone test which is commonly performed on amplifiers to determine their performance. There are two traces on the plot corresponding to the broadband noise output, labeled *Amplifier (Test Noise)*, and the two-tone output, labeled *Amplifier (Two Tone)*. Clicking on the legend entries for these two traces will

display the respective property panels. In the property panel for the Two Tone trace, you can set the levels and frequencies for the two-tone test input signal. Similarly, the noise level can be changed via the property panel for the Test Noise trace. By default, the two tones are placed about the amplifier's center frequency, spaced apart by 1 MHz.

Change the parameters for the two-tone test signal to those shown below and observe the change in the amplifier's output spectrum on the plot.

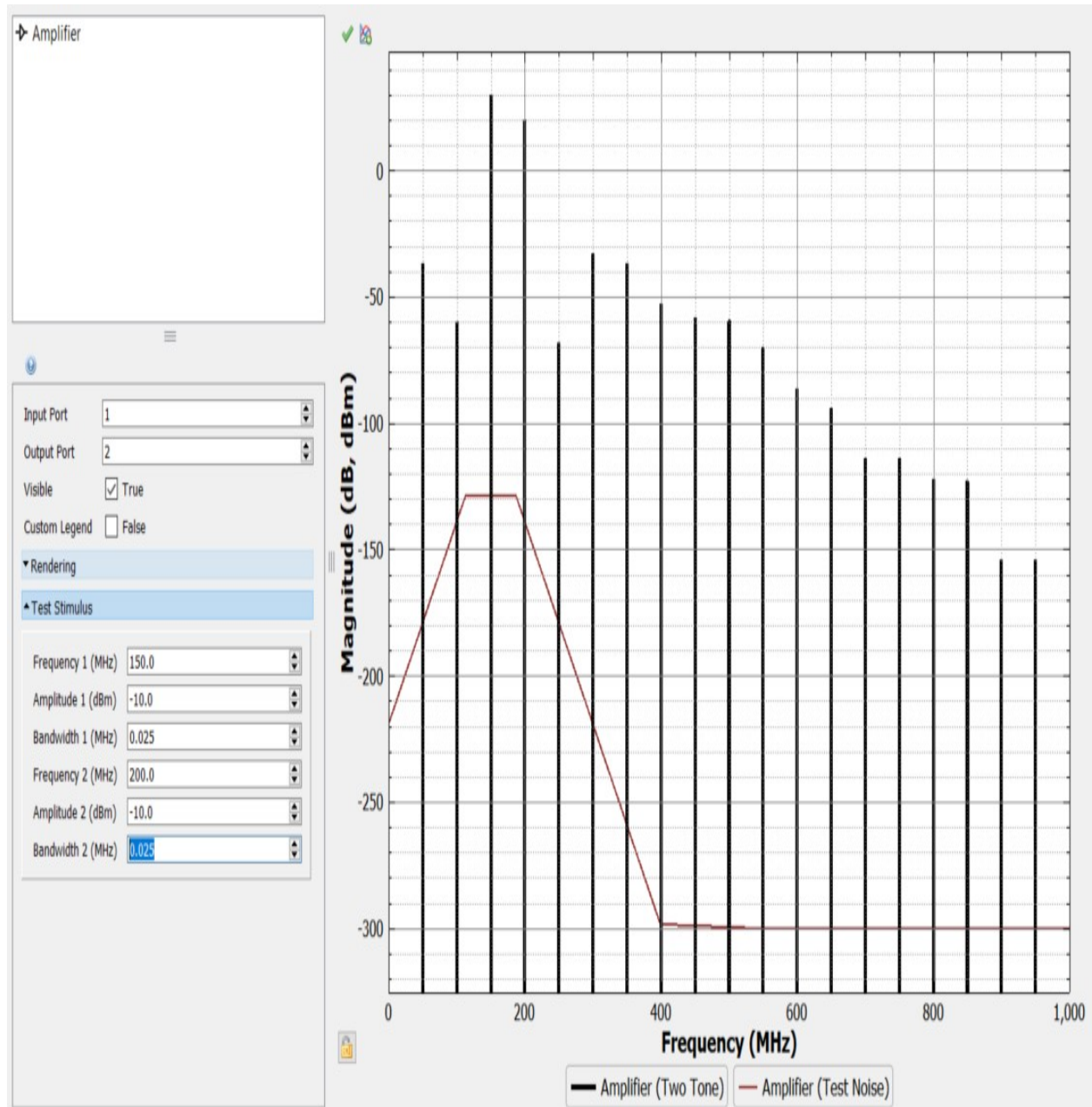

With the input signals (tones) at 150 MHz and 200 MHz, we see that in addition to amplified versions of these signals at the output, there are also a number of undesired intermod products at other frequencies that are the result of the nonlinear characteristics of the amplifier. Intermod

products such as these can be the cause of serious interference issues in cosite environments and are often hard to identify.

Click the X to close the amplifier's configuration dialog. At this point we are almost done with our schematic changes. Use the Schematic ribbon to add two antennas to the outputs of Tx-3 (Lo-UHF) and Tx-4 respectively. Then, double-click on the antenna to open the Coupling Editor and set the Antenna Noise Temperature = 0 K as we did for the other antennas.

Click the X to close the Coupling Editor. The schematic should now appear as shown below (antenna names may be different, but all the antennas are identical so that does not matter).

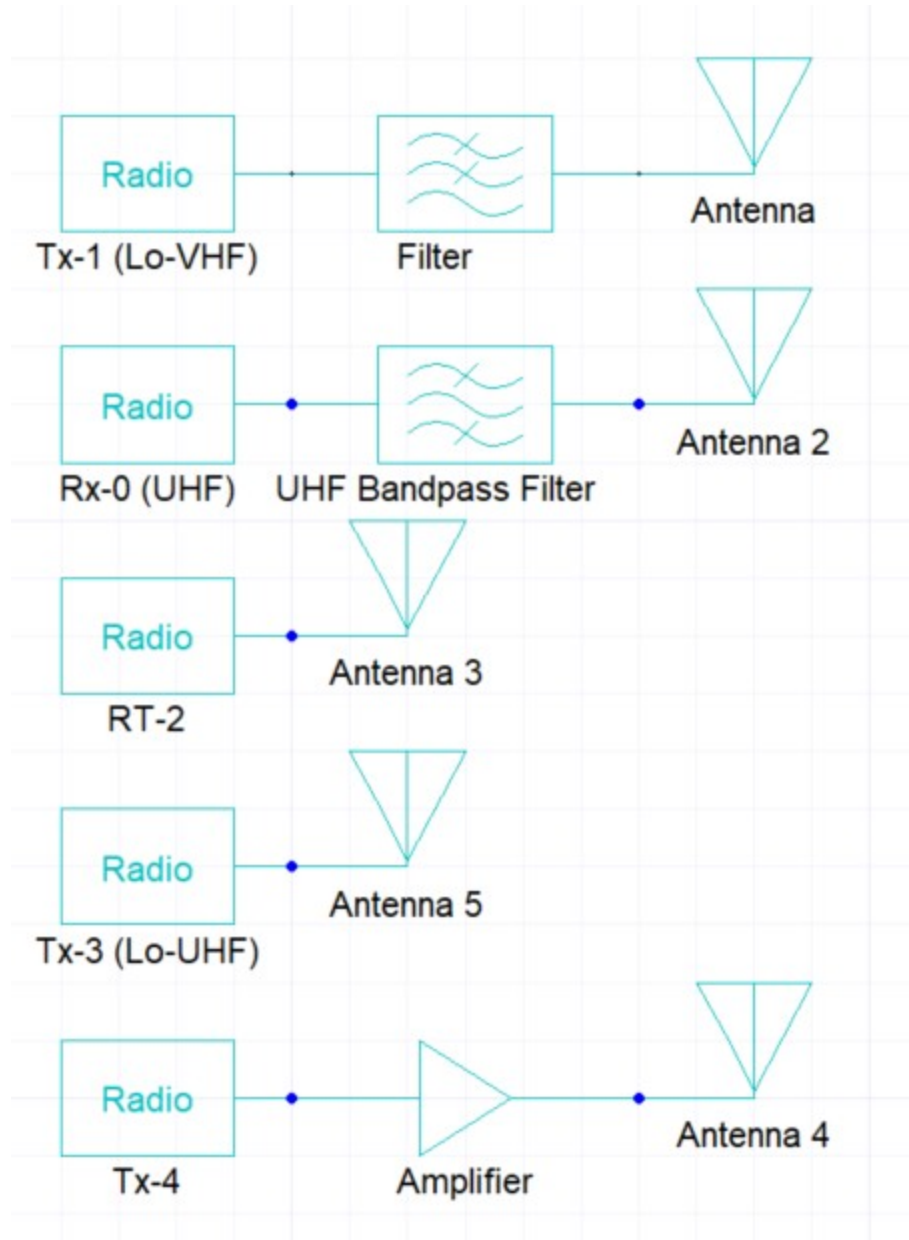

Open the Results dialog by right-clicking on the EMIT Design and selecting Analyze. First, we are going to examine and mitigate any interference issues associated with the 1-on-1 cases, when each transmitter is operating alone in the presence of the receivers. Once we mitigate all of the 1-on-1 interference issues, we'll analyze all of the transmitters operating simultaneously and explore any interference problems that result from this N-on-1 situation.

Select the Run icon (▶) to analyze all of the 1-on-1 interactions. The Scenario Matrix should appear as shown, where we see that Tx-4 is interfering with the RT-2 receiver.

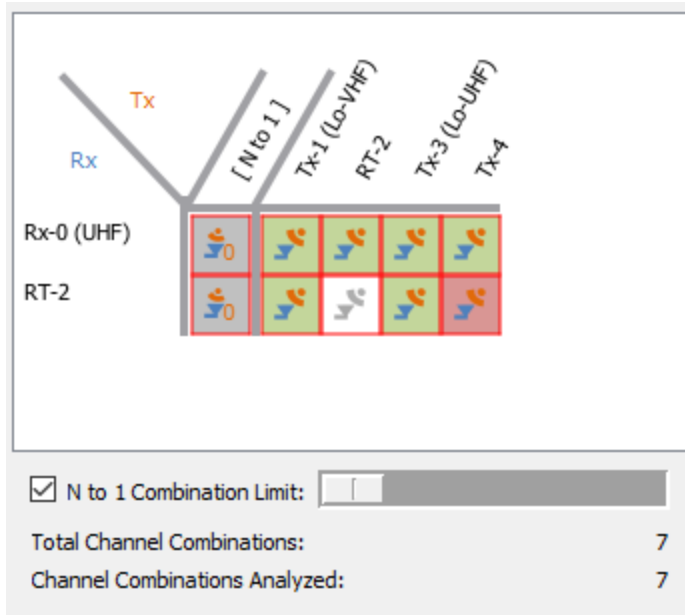

Select the Tx-4 vs RT-2 interaction square in the Scenario Matrix so that the Results Plot corresponds to this interaction. Examining the Results Plot, we see that the problem occurs outside of the receiver's tuned channel (out-of-channel interference) and is caused by Tx-4's fundamental at 150 MHz. This is quickly identified by looking at the plot marker (black arrow) and its associated label in the upper right of the plot which specifies the source (origin) of the interference. Since there is no Rx spurious response at 150 MHz, we can conclude that the 150 MHz component of the signal that reached the receiver's antenna port exceeds the saturation level (in this case +10 dBm) of the receiver.

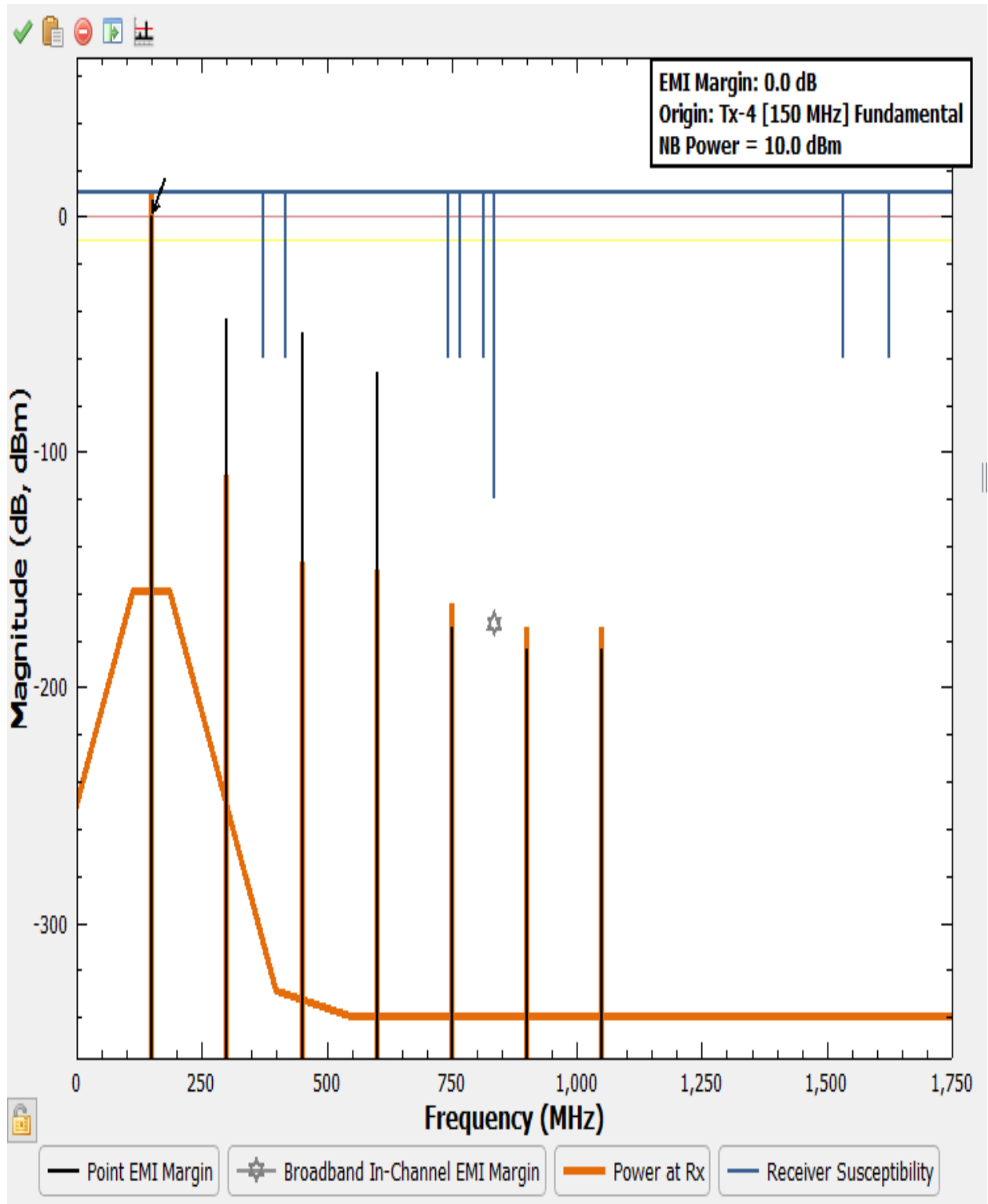

This out-of-channel interference can be controlled by placing a bandpass filter on the receiver's front-end. Close the Result Dialog via the "X" in the upper right corner. Right-click on any

Results folder and select **Keep Current Result**. Rename the kept result and add any desired notes.

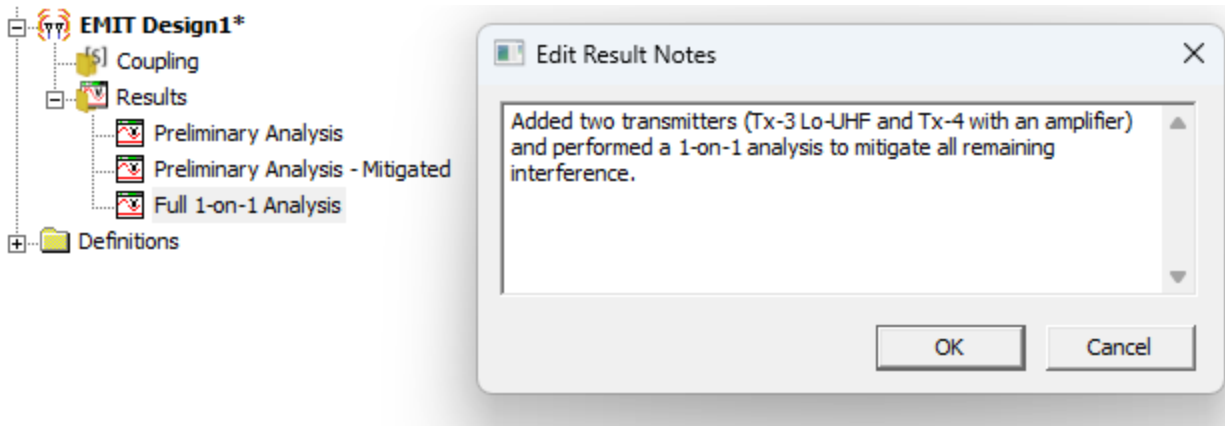

Disconnect the antenna from RT-2 by dragging the antenna to the left of the radio. Then use the Schematic ribbon toolbar to add a bandpass filter at the output of RT-2 and reconnect the antenna to the filter. Double-click on the filter to configure it as shown below.

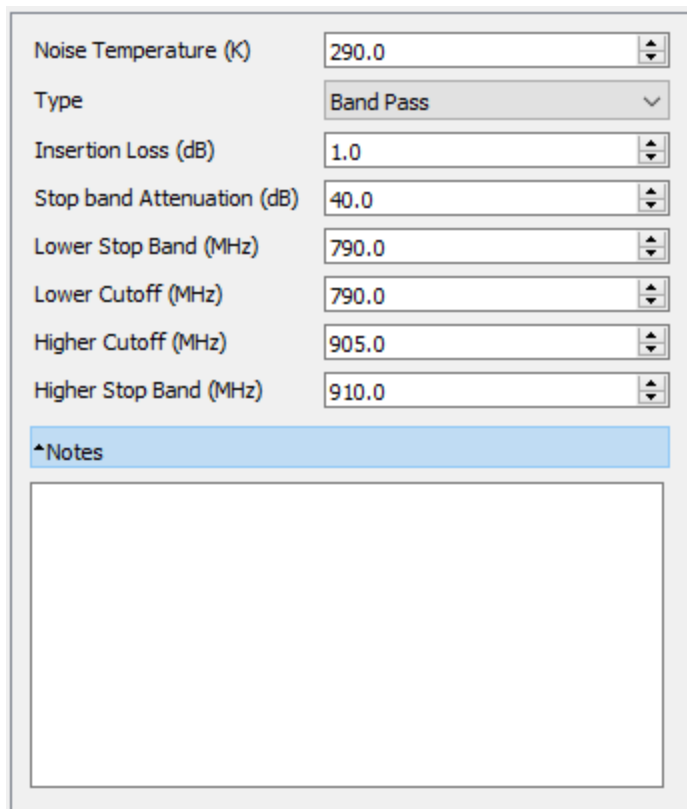

Click the X to close the filter's configuration dialog and open the Results Dialog again using one of the aforementioned methods. Re-run the simulation to see the effects of the added filter. As seen in the Scenario Matrix, the project is now interference free for all 1-on-1 transmit/receive pairs.



Now we wish to evaluate the N-on-1 scenarios to see how the system performs when multiple transmitters operate simultaneously. Looking at the Scenario Matrix, we see that we have 4 transmitters that can operate simultaneously and interfere with Rx-0 and 3 transmitters that can operate simultaneously and interfere with RT-2.

The entries in the [N to 1] columns for each receiver (row) show the resulting EMI margins for the receiver when there are N active transmitters in the row transmitting simultaneously. For our current scenario, we see that RT-2 does not experience any interference with all the transmitters operating, but Rx-0 does.

The screenshot displays the EMIT software interface. At the top, a diagram shows a receiver (Rx) and four transmitters (Tx-1, Tx-2, Tx-3, Tx-4) with their respective frequency bands: Tx-1 (Lo-VHF), RT-2 (Hi-UHF), Tx-3 (Lo-UHF), and Tx-4. Below this is a scenario matrix table with two rows (Rx-0 (UHF) and RT-2 (Hi-UHF)) and five columns (Tx, [N to 1], Tx-1 (Lo-VHF), RT-2 (Hi-UHF), Tx-3 (Lo-UHF), Tx-4). The matrix cells contain icons representing EMI margins. The top-left cell (Rx-0, Tx) is highlighted in red. Below the matrix is a control panel with a checkbox for 'N to 1 Combination Limit' which is currently checked. Below the checkbox, the 'Total Channel Combinations' and 'Channel Combinations Analyzed' are both listed as 9.

Deselect the **N to 1 Combination Limit** check box to disable the limit.



Select the Run icon (▶) to analyze all of the N-on-1 interactions.

The entries in the [N to 1] columns for each receiver (row) show the resulting EMI margins for the receiver when there are N active transmitters in the row transmitting simultaneously. For the current scenario, note that RT-2 does not experience any interference with all the transmitters operating, but Rx-0 does.

Select the red Scenario Matrix square and look at the Results Plot.

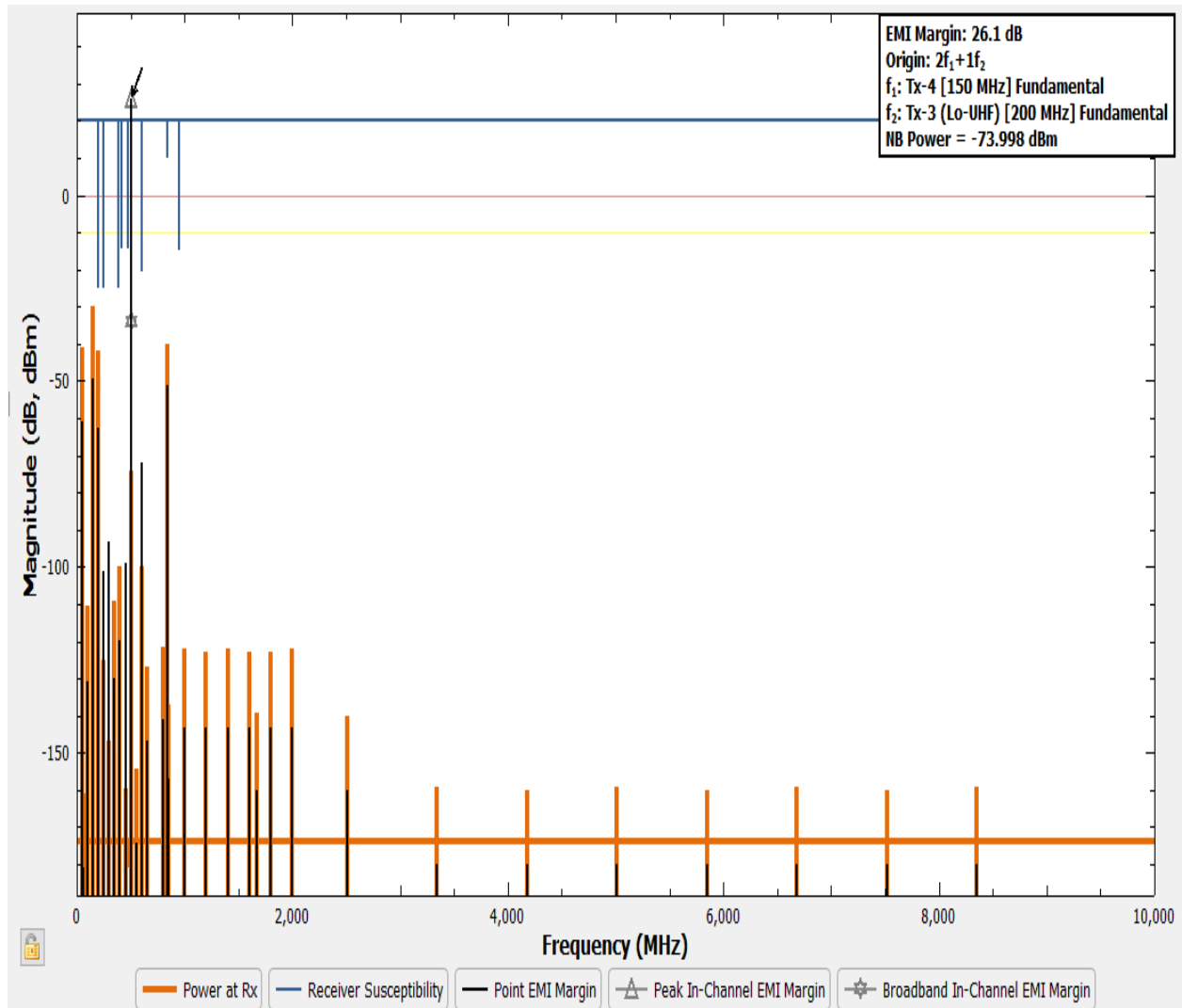

Notice that the Power at Rx (click on the legend entry for emphasis) has many narrowband components, far more than just the fundamental and harmonics we defined. This is because the results are for all transmitters operating simultaneously. For our case, each of our transmitters operates on only a single channel, but if they had multiple channels, then the results plot display would show the worst case transmit channel combination.

Before analyzing the above plot in any detail, let's look at the Interaction Diagram. The Interaction Diagram is an extremely powerful tool for determining the source of the issue. With the [N to 1] vs Rx-0 square in the Scenario Matrix selected, the Interaction Diagram should appear as below. The orange labels on each transmitter specify the transmit channel that contributes to this worst case interference and the orange line shows the path that the worst-case interference takes from the transmitter (or transmitters) to the receiver. As seen in the image below, the 200 MHz channel from the Tx-3 Lo-UHF radio couples into the Tx-4. It then mixes with the 150 MHz channel from the Tx-4 radio and is re-radiated to the Rx-0 radio where it interferes with the 500 MHz channel.

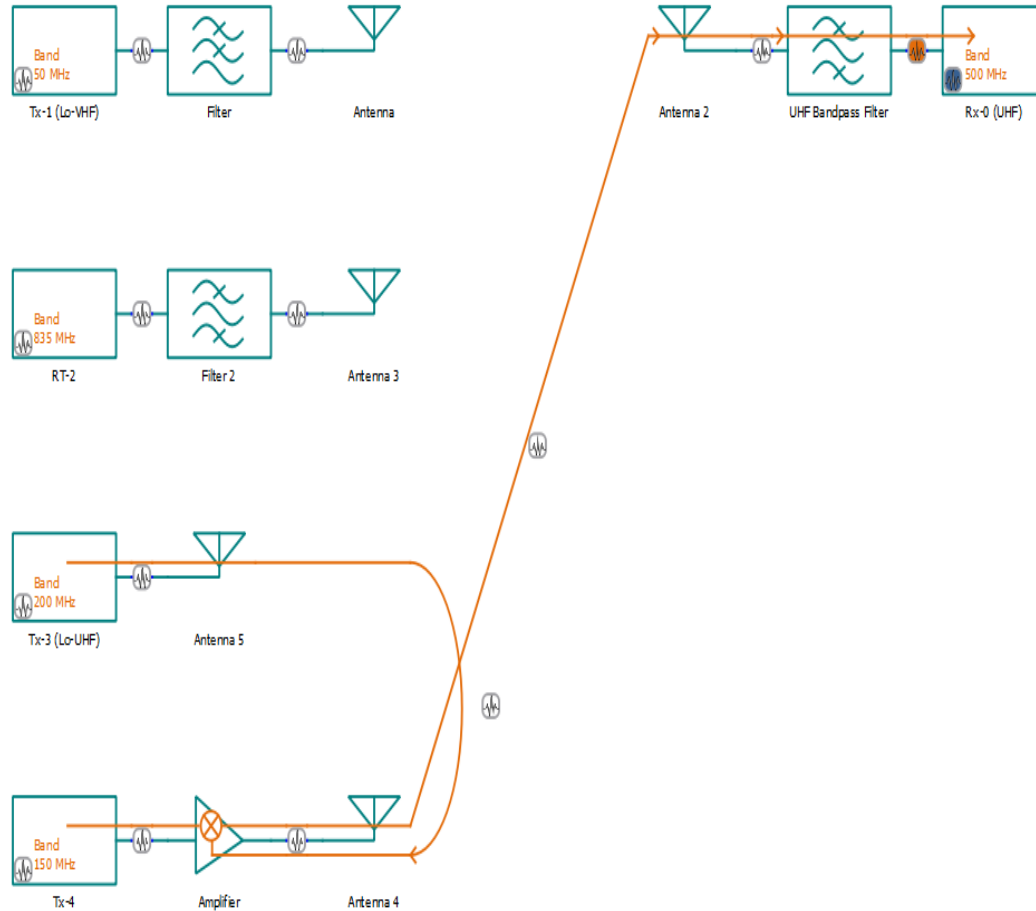

To get more details on the interference, we can go back to our Result Plot. The plot marker automatically identifies the worst-case interference for the selected receiver, which corresponds to the red path we just analyzed in the Interaction Diagram. Referring to the plot marker's label, we see that the EMI Margin = +26.1 dB and that it is the result of the 2nd harmonic of the Tx-4 fundamental ($2f_1$) mixing with the fundamental from Tx-3 ($2 \times 150 \text{ MHz} + 200 \text{ MHz} = 500 \text{ MHz}$).

EMI Margin: 26.1 dB

Origin: $2f_1 + 1f_2$

f_1 : Tx-4 [150 MHz] Fundamental

f_2 : Tx-3 (Lo-UHF) [200 MHz] Fundamental

What we are seeing here is often referred to as inter-Tx intermod. The signal from Tx-3 is coupling into Tx-4. A portion of the coupled signal finds its way to the input of the amplifier based on the reverse isolation specified for the amplifier. It then combines with the output of Tx-4 at the input to the amplifier resulting in the problematic third order intermod product at 500 MHz. This is shown in the figure below. Note that the signal at Rx-0 also includes the direct contribution from each transmitter (but for clarity this is not shown in the figure).

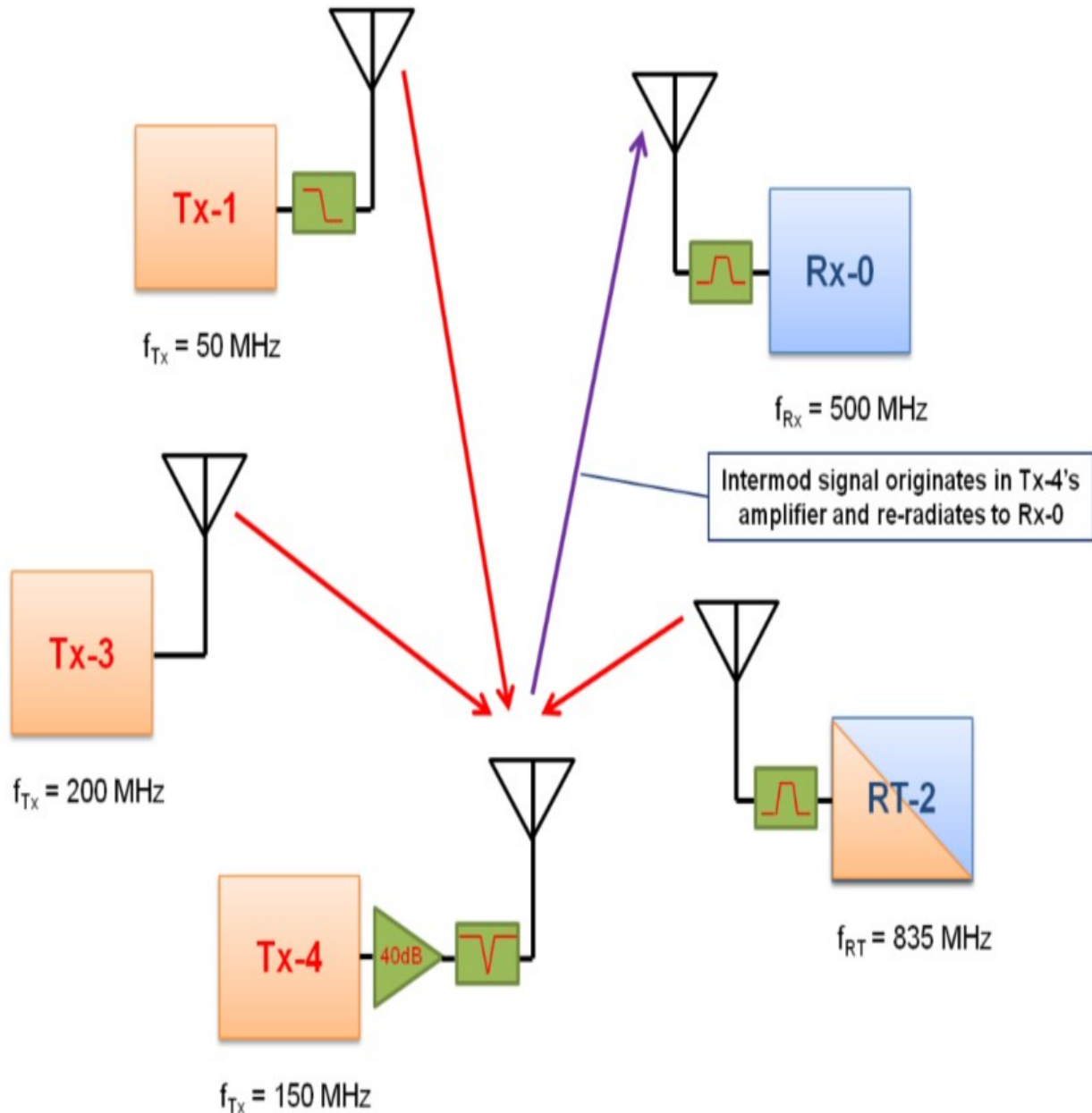

The figure above also shows a filter on Tx-4 that we now wish to add. In order to mitigate this inter-Tx intermod problem, we need to prevent the 200 MHz signal from Tx-3 from reaching the amplifier on Tx-4. We will add a notch filter to accomplish this as shown.

Close the results dialog by clicking the "X" in the upper right corner. Disconnect the antenna from the amplifier by dragging it to the left of the amplifier. Select the amplifier and then add a Band Stop filter from the Filter drop down menu in the Schematic ribbon toolbar. Rename the filter 200 MHz Notch. Select the antenna and click **Reposition** to connect it to the new band stop filter.

Double-click on the 200 MHz Notch filter and set the parameters as shown below.

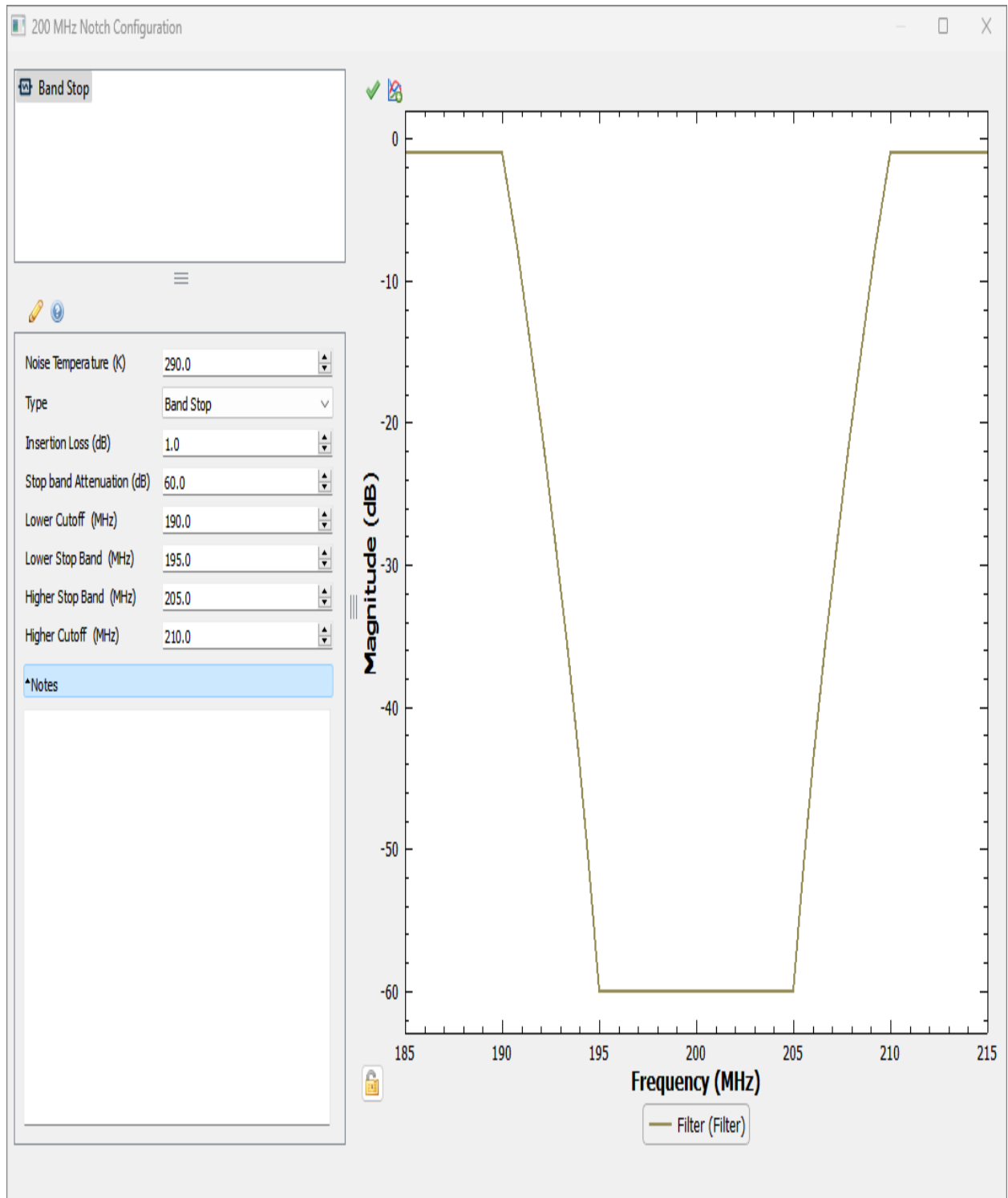

Add Additional Tx's to the Scenario 3-15

Click the X to close the filter's configuration dialog box. Verify that your schematic matches the one below (note: some antenna names may differ, but since the antennas are all identical, it will not affect the results).

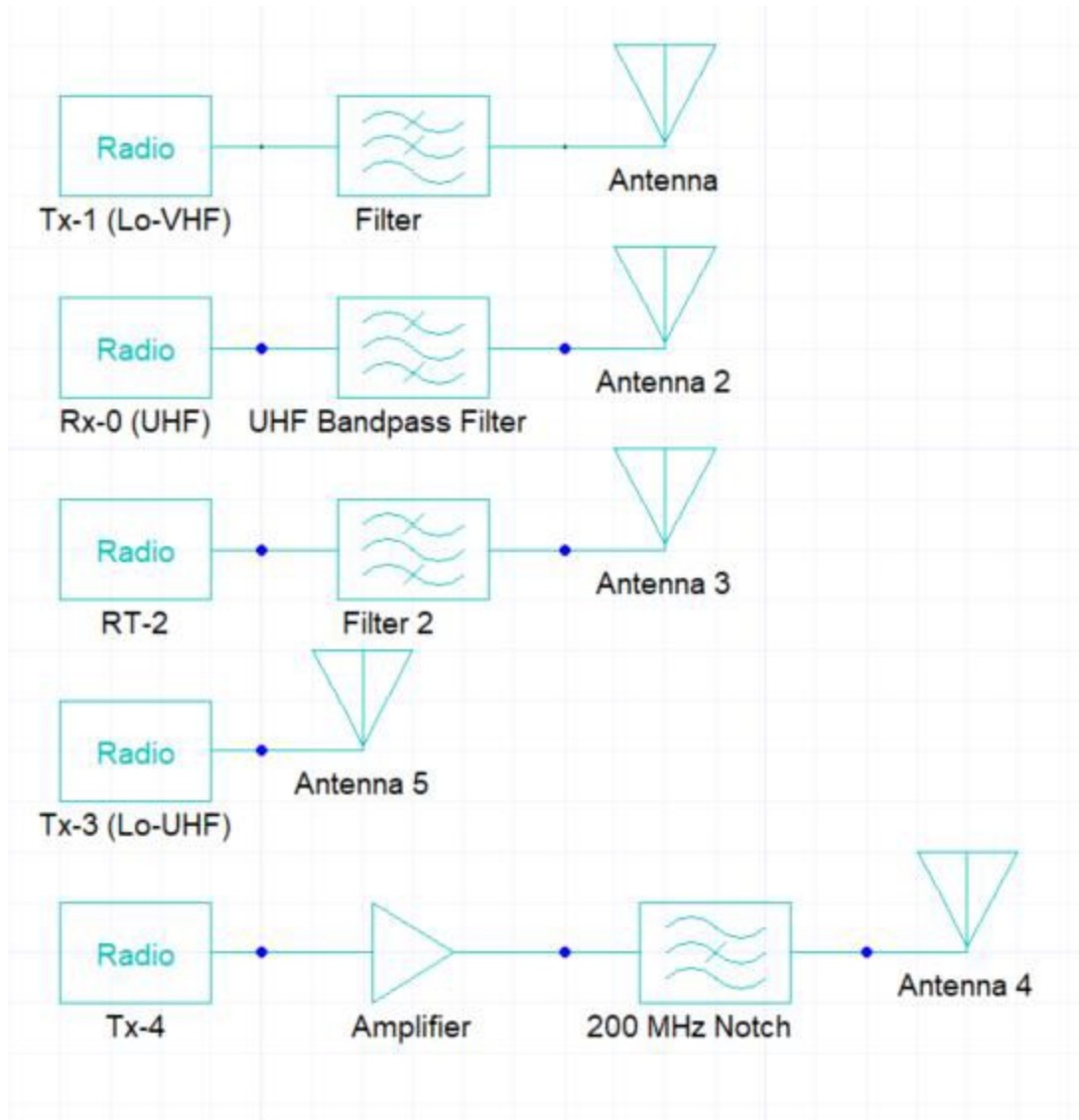

Open the Results Dialog again and re-run the simulation. The Scenario Matrix shows that the band stop (notch) filter successfully mitigated all the interference as shown by the completely green Scenario Matrix.

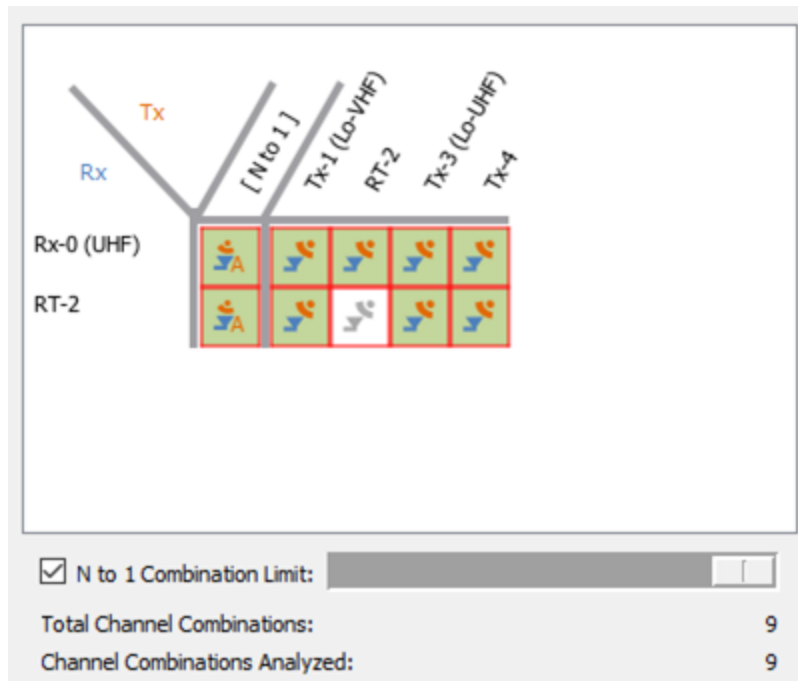

One more thing to note is that the order of the outboard components is very important. When we added the notch filter in the previous step, it was added between the amplifier and antenna which is where we wanted it. However, to see the effect of component placement, move the filter so that it is located between the radio and amplifier. Re-run the simulation and note that the inter-mod problems are back. This is because with the filter in this position, the 200 MHz signal from Tx-3 (and the 50 MHz signal from Tx-1) is not prevented from coupling into the output of the amplifier.



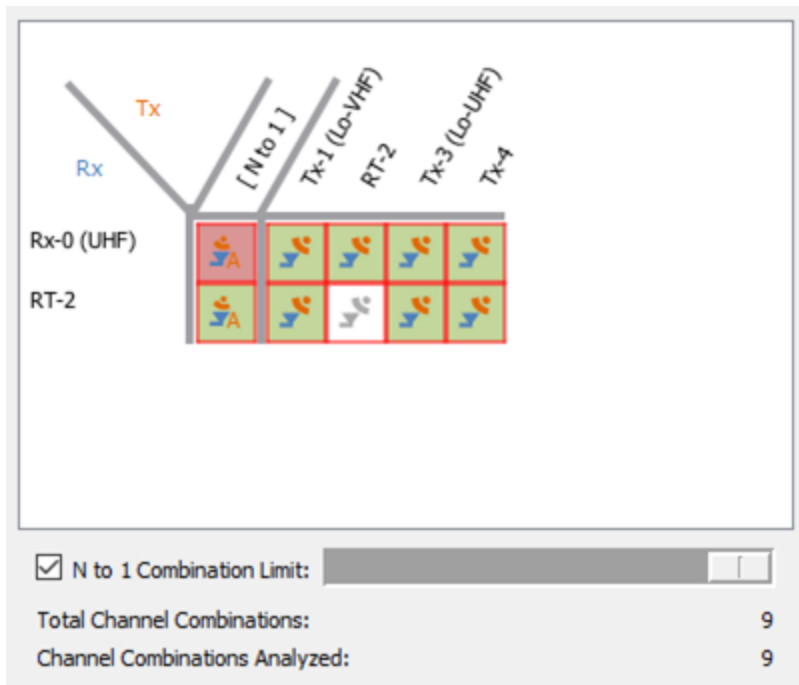

Move the filter back to its original location and save your project.